

Reversible Motor

180 Watt

Frame Size: 90 mm

30 Minute rating, TEFC Aluminium Body.
 Quick Reversal of Direction of Rotation.
 Continuously Acting Internal Brake.
 Terminal Box or Open Lead Wires for Connection.



Specifications:

Model	Supply Voltage	Frequency Hz	Current A	Starting Torque N.m	Rated Torque N.m	Rated Speed RPM	Capacitor µF
90 IW 2□ 180	Single Phase 110V	60	2.70	0.51	0.57	3000	20
90 IX 2□ 180	Single Phase 230V	50	1.35	0.63	0.69	2700	6
90 IY 4□ 180	Three Phase 230V	60	1.30	1.23	1.11	1600	---
90 IY 4□ 180	Three Phase 230V	50	1.60	1.50	1.40	1250	—
90 IY 4□ 180	Three Phase 415V	50	0.80	1.50	1.40	1250	—

□ Type Of Shaft, G for Gear Shaft, R for Round Shaft

Gearmotor Torque Table:

The maximum permissible torque is 20 N.m

50 Hz

Unit : N.m

RPM	500	416	300	250	200	166	120	100	83	60	50	41	30	25	20	16	15	12.5	10	8.3
Gear Ratio	3	3.6	5	6	7.5	9	12.5	15	18	25	30	36	50	60	75	90	100	120	150	180
Output Torque	3.4	4.1	5.7	6.8	8.5	10.2	12.8	15.3	18.4	20.0	20.0	20.0	20.0	20.0	20.0	20.0	20.0	20.0	20.0	20.0

60 Hz

Unit : N.m

RPM	600	500	360	300	240	200	144	120	100	72	60	50	30	30	24	20	18	15	12	10
Gear Ratio	3	3.6	5	6	7.5	9	12.5	15	18	25	30	36	50	60	75	90	100	120	150	180
Output Torque	2.8	3.4	4.8	5.6	7.2	8.6	10.6	12.8	15.4	19.4	20.0	20.0	20.0	20.0	20.0	20.0	20.0	20.0	20.0	20.0

The Gear boxes are sold separately.

A coloured background indicates gear shaft rotation in same direction as motor shaft.

A white background indicates gear shaft rotation in opposite direction to the motor shaft.

The speed of geared motor is calculated by dividing motor's synchronous speed by the gear ratio.

The actual speed is less than the displayed value, depending upon the load.

Characteristics, specifications and dimensions are subject to change without notice.

Dimensions

Motor, Gearbox with Terminal Box

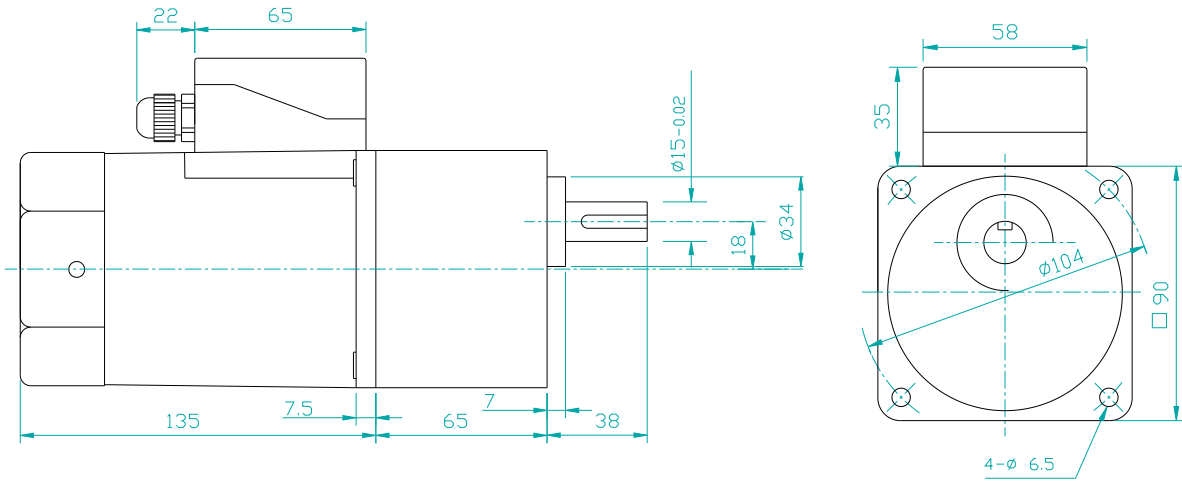

Motor Round Shaft with Terminal Box

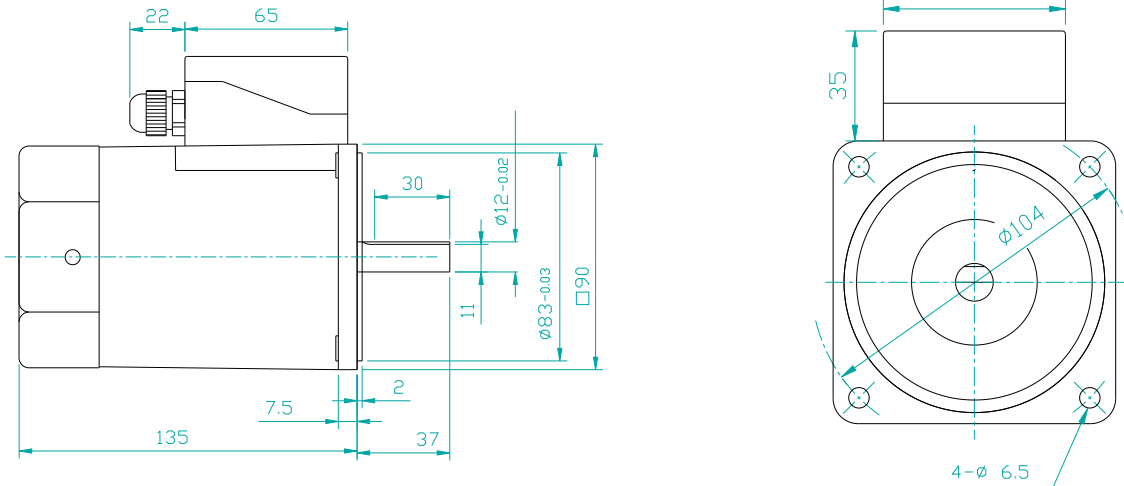

Motor, Gearbox with Lead Wires

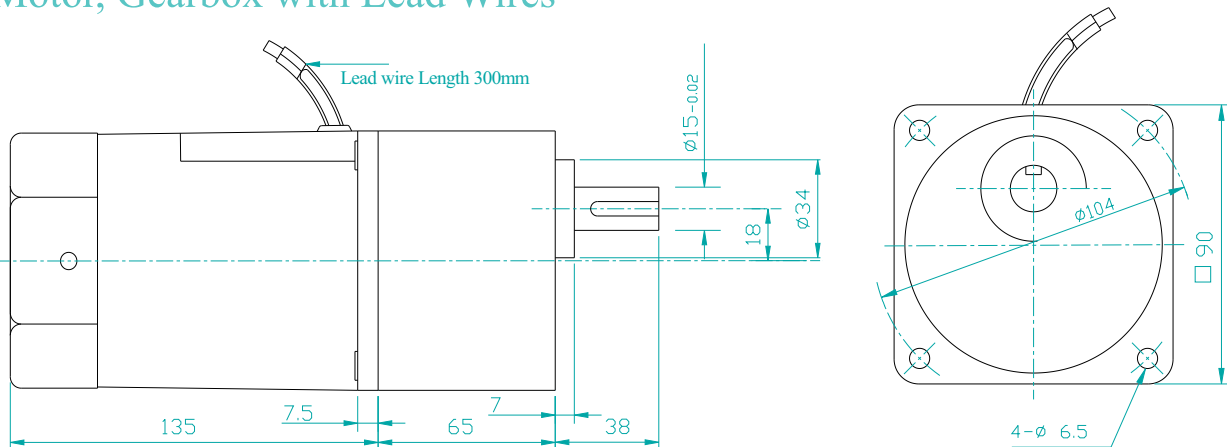

Key & Keyway

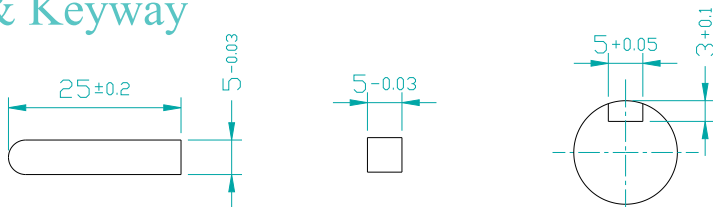

Weight: Motor 3 Kg

Gear Box 1.5 Kg

Reversible Motor

Wiring Diagram:

Wiring Diagram for Single Phase Motor

<p>Short Black wires and connect as shown to rotate the motor in clockwise direction. To change the direction, flip CW to CCW.</p>	<p>Red wires are for running winding & Black wires are for starting winding. To change the direction, interchange Black wires or Red wires.</p>

Wiring Diagram for Three Phase Motor

<h4>Star Connection</h4>	<h4>Delta Connection</h4>
<p>To change the direction, interchange any two wires between U, V & W. For 415 Volt supply, wires are connected as shown. Short White, Black & Blue wire and then insulate properly.</p>	<p>To change the direction, interchange any two wires between U, V & W. For 230 Volt 3 Ph supply, wires are connected as shown.</p>

Change the direction of the motor only after it stops rotating. If the attempt is made during rotation, motor may ignore the reversing command or change the direction after some time.